

END VIEW A

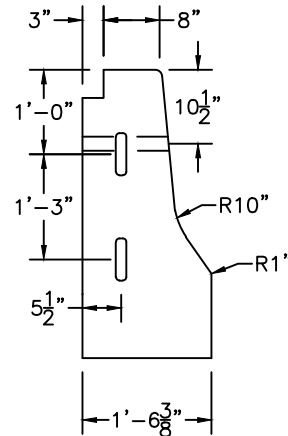

END VIEW B

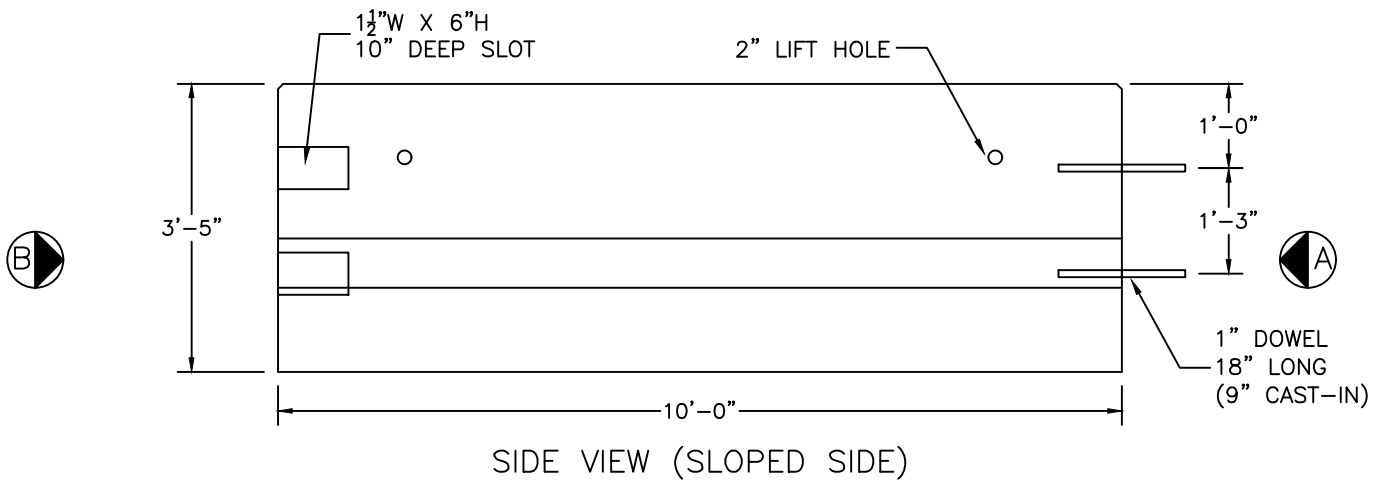

SIDE VIEW (SLOPED SIDE)

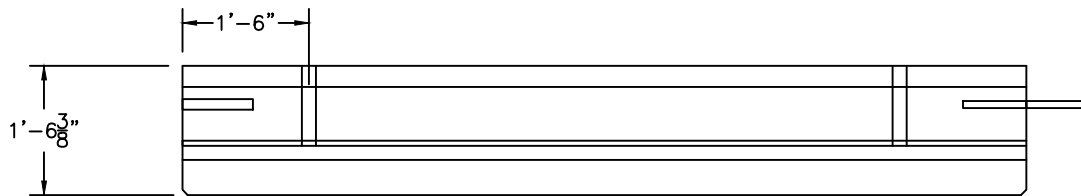

TOP VIEW

NOTES:

- 1) CONCRETE: 4,000 PSI MINIMUM AFTER 28 DAYS.
- 2) DOWELS 1" DIA 18" LONG SMOOTH BAR GALVANIZED, AASHTO-M31, GRADE 60.
- 3) MINIMUM COVER OF 1 1/2" UNLESS OTHERWISE SPECIFIED.
- 4) REINFORCEMENT TO BE GALVANIZED OR EPOXY COATED, AASHTO-M31, GRADE 60.
- 5) BARRIERS CURED USING STARSEAL 1315 CURING COMPOUND/SEALER, MEETS REQUIREMENTS OF ASTM C1315 TYPE 1 CLASS A.
- 6) INSPECTION TO BE PERFORMED BY THE MASSACHUSETTS DEPARTMENT OF TRANSPORTATION OR DESIGNATED REPRESENTATIVE.
- 7) ITEM NO TP-MBFSSFNS. WEIGHT 5,900LBS.

SHEA PRODUCT ID:
MBTFSF10-41SLAB

PREPARED FOR:

FILE NAME:
medbarsf10nslab.dwg

WEIGHT (LBS):
5,900#

DRAWN BY:
ARO

DATE:
06/01/18

PAGE:
J4.9

