

PLAN VIEW

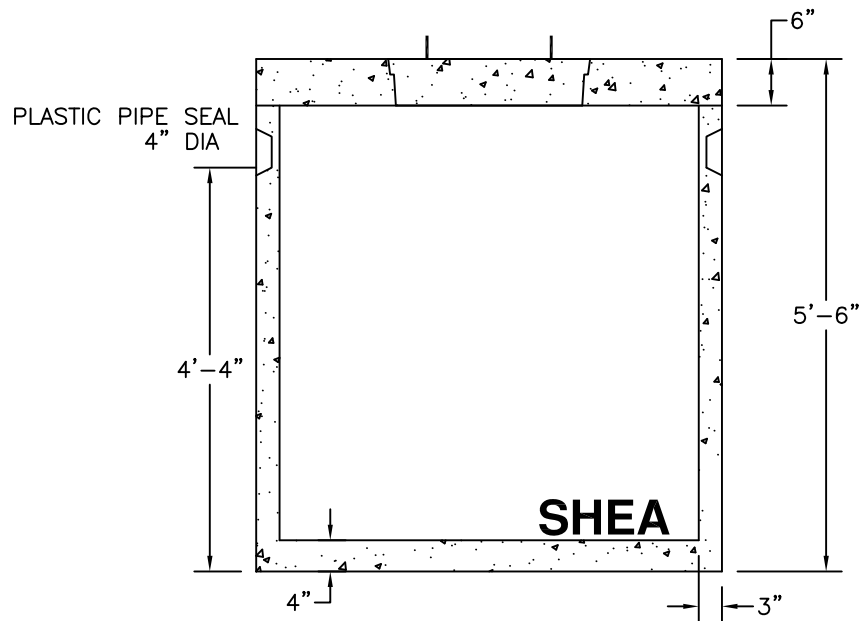

SECTION VIEW

NOTES:

1. CONCRETE: 4,000 PSI MINIMUM AFTER 28 DAYS.
2. DESIGN CONFORMS WITH 310 CMR 15.000, DEP TITLE 5 REGS, FOR PUMP CHAMBERS.
3. ALL REINFORCEMENT PER ASTM C1227-93.
4. ALSO AVAILABLE IN H-20 LOADING.
5. JOINT SEALED WITH BUTYL RESIN.
6. PUMPS AND ACCESSORIES OPTIONAL.

			WEIGHT
ITEM NO.	TK-5X5PC	STANDARD	6,000#
	TK-5X5PCH	H-20	6,600#



*New England's Premier Precaster*  
 800-696-7432 (SHEA)  
 www.sheaconcrete.com

PUMP CHAMBER  
 500 GALLON

773 Salem Street  
 P.O. Box 520  
 Wilmington, MA 01887

87 Haverhill Road  
 P.O. Box 807  
 Amesbury, MA 01913

160 Old Turnpike Road  
 Nottingham, NH 03290

Page: C1. 2

pc500.dwg

11/30/2009

