

PLAN

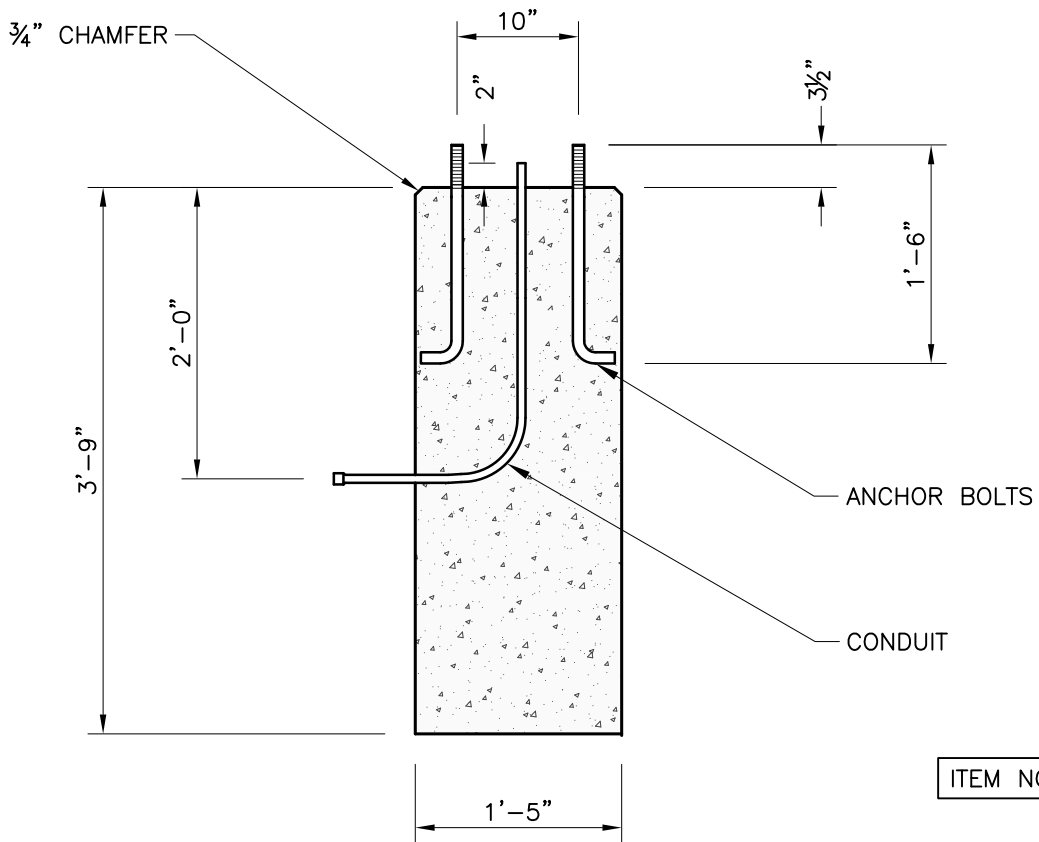

WEIGHT	
ITEM NO. LPB17R	875#

SECTION A-A

NOTES:

1. CONCRETE MINIMUM STRENGTH 4,000 PSI AFTER 28 DAYS.
2. CONDUIT, ANCHOR BOLTS AND TEMPLATE SUPPLIED BY OTHERS.
3. LIGHT POLE BASE SIZE IS TO BE SPECIFIED BY A QUALIFIED ENGINEER.



New England's Premier Precaster

800-696-7432 (SHEA)

www.sheaconcrete.com

LIGHT POLE BASE
17" DIAMETER

773 Salem Street—Wilmington, MA
87 Haverhill Road—Amesbury, MA

153 Cranberry Hwy—Rochester, MA
160 Old Turnpike Rd—Nottingham, NH

Mail to: PO Box 520—Wilmington, MA 01887

Page: K1.1

lpole17r.dwg

01/01/2013

