

PLAN

NOTES:

1. CONCRETE MINIMUM STRENGTH 5,000 PSI AFTER 28 DAYS.
2. STEEL REINFORCEMENT – ASTM A615, GRADE 60.
3. MINIMUM STEEL COVER – 1 INCH.
4. DESIGN LOADING – AASHTO HS20-44.



New England's Premier Precaster
 800-696-7432 (SHEA)
 www.sheaconcrete.com

6' X 13' UTILITY VAULT/MANHOLE
NGRID – UM22

773 Salem Street—Wilmington, MA 153 Cranberry Hwy—Rochester, MA
 87 Haverhill Road—Amesbury, MA 160 Old Turnpike Rd—Nottingham, NH
 Mail to: PO Box 520—Wilmington, MA 01887

Page: K5.8.1
 NGRID UM22.dwg

01/01/2013



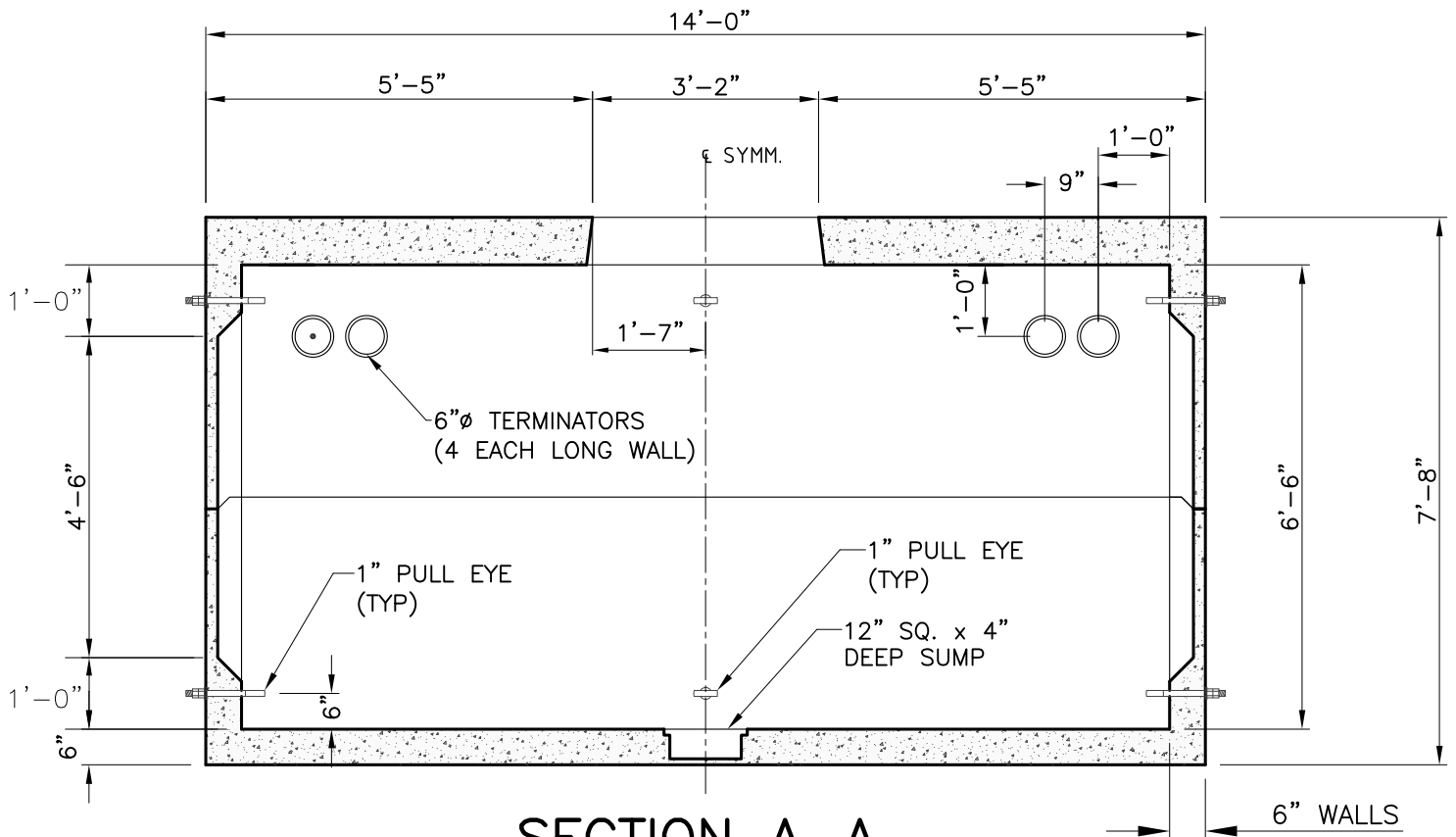

SECTION A-A

OPPOSITE WALLS ARE MIRROR IMAGES.

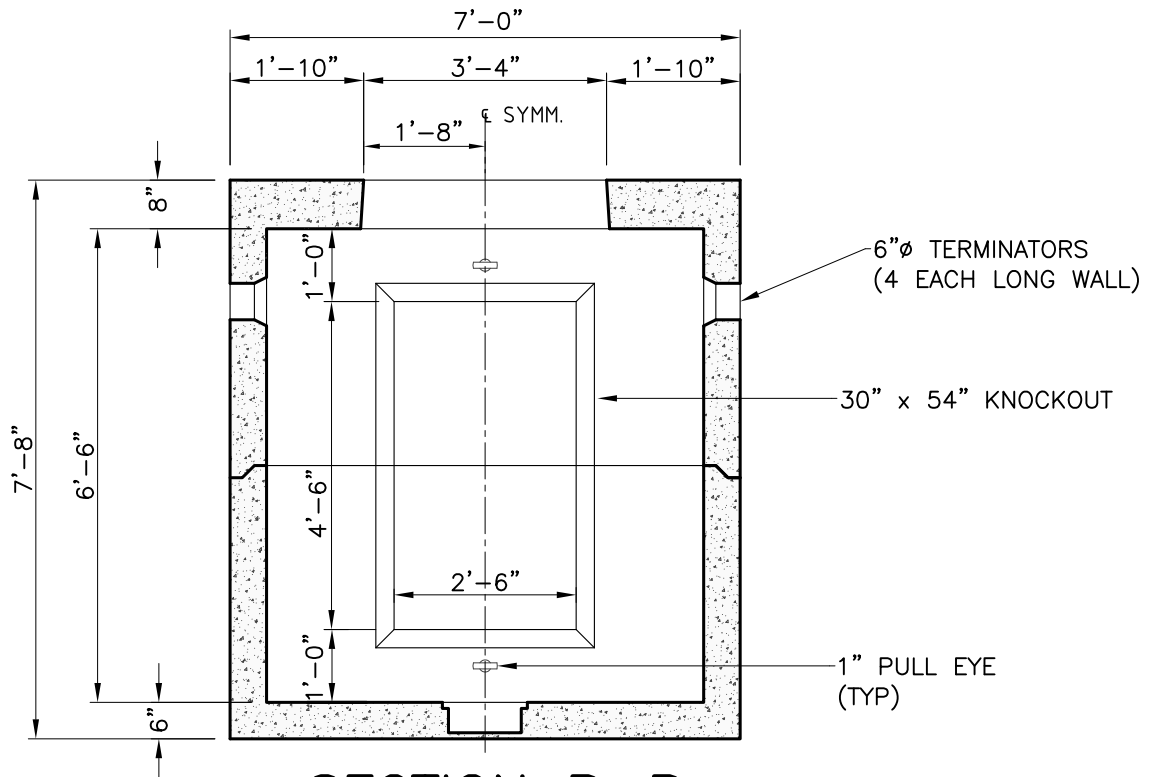

SECTION B-B

OPPOSITE WALLS ARE MIRROR IMAGES.



New England's Premier Precaster
 800-696-7432 (SHEA)
 www.sheaconcrete.com

6' X 13' UTILITY VAULT/MANHOLE
 NGRID - UM22

